

# BICYCLE STAMPS

OFFICIAL PUBLICATION OF THE BICYCLE STAMPS CLUB  
BS 79 March 2015



President/Treasurer: Brian Sole. Secretary Ralph Letsch. V-President: Jari Majander  
Acting Editor: Brian Sole,

email: [brian.sole@btinternet.com](mailto:brian.sole@btinternet.com)

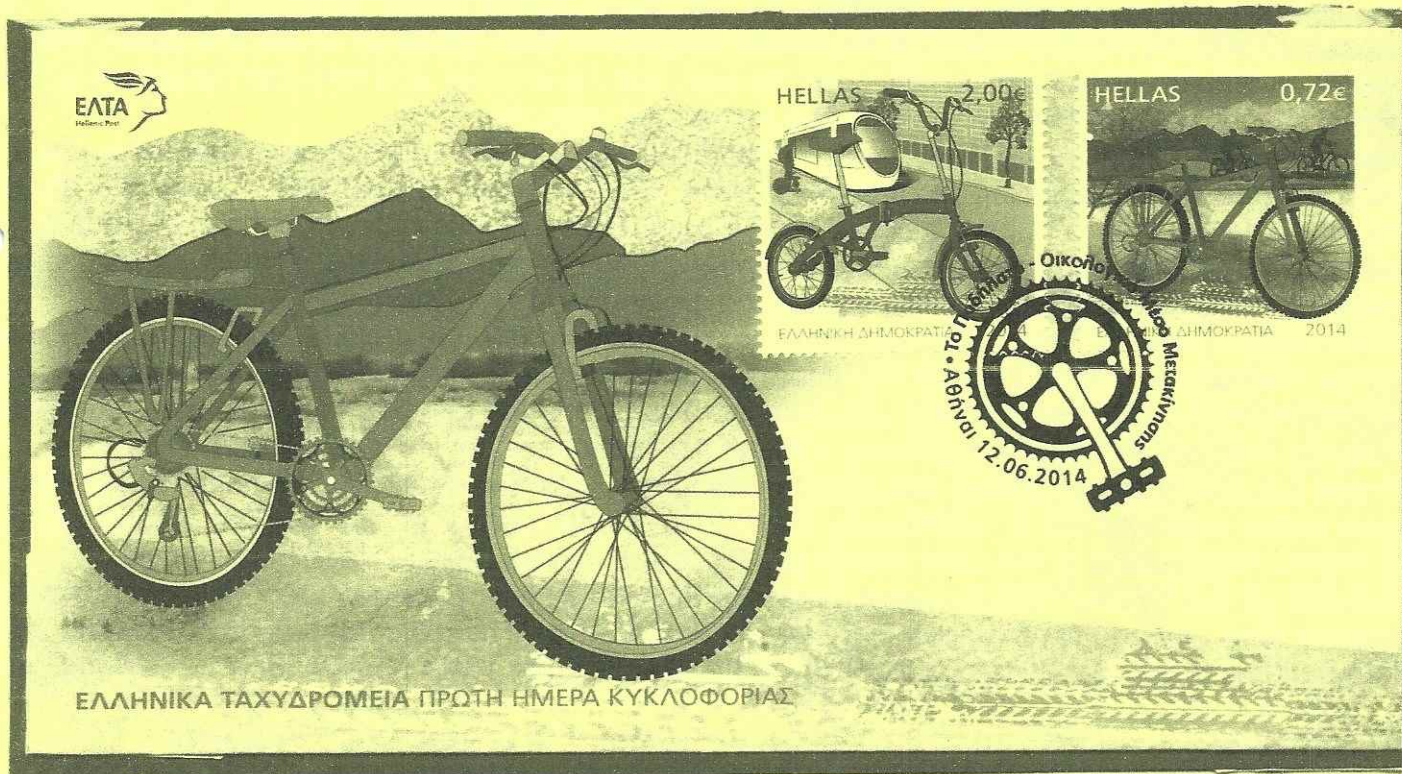

## Moving from Car to Bike?

"Bicycles are cheap and quiet, don't pollute, don't take up space and are fun even for grown-ups. Cycling allows you to freely enjoy the city and its public spaces and moving around becomes a pleasant break between work and obligations.

Anyone who leaves the car behind having been won over by the advantages bicycles have to offer discovers a different lifestyle and see his day-to-day life filled with colour, fun, vitality, as his day becomes more pleasant and civilised. Cycling makes you healthier."

*From the Presentation Pack Hellenic Post 12.06.14*

A bicycle stamp checklist is maintained and is available from Piet Hein Hilarides  
The Netherlands. [p.h.hilarides@chello.nl](mailto:p.h.hilarides@chello.nl)

Membership enquiries should be sent to either Ralph Letsch at  
Luxembourg or

Steven W Andreasen

Email: [steven.w.andreasen@gmail.com](mailto:steven.w.andreasen@gmail.com)

USA



# Editorial

## FROM THE PRESIDENT

It is a pleasure to welcome a new member of the Bicycle Stamps Club – **Edward Muench** of New Jersey, USA. I have included Edward on the Club Roster.

I am grateful to Steve Andreasen for taking over the role of USA treasurer from Bill Eubanks and for keeping me up to date on renewals by members. Before Steve accepted the position he explained that he and his wife took an annual vacation in New Zealand. In his first email, after 2 weeks in Napier, New Zealand this year, he said that he and his wife had just cycled along the Pacific beach north of the city, in warm sun and gentle breezes!

Membership is keeping up fairly well. I have included on the Club Roster members whose subscription was outstanding at December 2014, with the word "OVERDUE". I hope that those members will submit a subscription as soon as possible. Please note, members who have an asterisk (\*) against their names are due to renew during the next 5 months. In most cases it is not payable immediately, but do make a note of the month that your subscription is due.

Once again I wish to thank Thomas Matthies for providing the "New Issue Update", I know that some members are keen to have this information. Also, I have included some of the many items submitted by Arnoldt Rehm. Thank you Arnoldt. His plea in the last issue for members to receive "Bicycle Stamps" by email brought only a handful of responses; most wanted hard copies.

There is a mixed bag of articles including the San Francisco-Fresno bicycle mail of 1894, a private post which operated on St Valentine's Day 1971, a brief history of the Cyclists' Touring Club, formed in 1878 and a continuation of the annual East European Peace Race handstamps.

Included in the STOP PRESS page is an offer from Steve Malone for members to acquire bicycle stamps from him and confirmation that I will be at the British Thematic Association's table at the International Stamp Exhibition EUROPHILEX London 2015 on 13/14 May 2015. **Brian Sole**

## CONTENTS

	Page(s)
FDC Greece 12.06.14 The Bicycle Ecological means of Transport	Front page
Editorial & Index	2
New Issues by Thomas Matthies	3 – 16
Carbon fibre £1.28 stamp issued by Royal Mail 19.02.2015	17
Fresno and San Francisco Bicycle Mail 1894	18-19
Cyclists' Touring Club 1897 wrapper and 1928 labels	20
Cyclists' Touring Club History by Brian Mynott	21
Fight for free carriage of bicycles on trains USA 1896 Arnoldt Rehm	22
Postmen using a bicycle subject to 4-yearly medical exam.	23
Cycle advert. 1934 Danish Booklet & North Korea slogans	24
Valentine's Day Private Post Mark & Moody Ltd 1971	25
The Morocco Agencies Cycle Post by Richard Garcia	26-27
The Berlin-Warsaw-Prague "Peace Race" handstamps (cont.)	28-33
Club Roster	34-35
Have you seen these before? Queries raised by Arnoldt Rehm	36
Financial Reports	37
Bicycle Advertising Envelope USA 1904	38
STOP PRESS! Steve Malone selling bicycle stamp collection	39
"Wot no Cycles?!" submitted by Arnoldt Rehm	40



# New Issue Update

ANDORRA (SPANISH)	21.2.13	St	0,75 €	OPENING OF THE ROAD BETWEEN ANDORRA AND SEU D'URGELL 1913 / Historic photo - people on the roadside - 2 of them with bicycle	1→Pn(50)	79-07, {§}, [XC002.13]
ARGENTINA	27.4.13	St	3,50 \$	400TH ANNIVERSARY OF THE NATIONAL UNIVERSITY OF CORDOBA / Silhouettes of people, one with a bicycle	1→Pn(?)	79-07, {§}, [AR009.13]
AUSTRALIA <sup>1</sup>	?.11.14	MS	2 x 70 c	BUSH BALLADS - 150TH BIRTHDAY OF ANDREW BARTON "BANJO" PATERSON / Miniature Sheet with 2 of the stamp from 13.5.14 - no bike motif in margin (Part of the "Bush Ballad Collection". Price = \$129,95 FV of stamps = \$8,40		79-14, {§}
		CShl		AUSTRALIAN STAMPS 2014 / "Commemorative Landscape" - numbered Composite Sheetlet of 28 diff. Stamps incl. th one from 13.5.14 - stamp may differ from the original - no bike motif in margin (Part of the "2014 multisheet set". Price = \$899,95 FV of stamps = \$85,50; limited to 500) Both editions offered in the catalogue "Celebrating the Moment & Preserving The Past"		79-14, {§}
* BULGARIA	14.5.14			135TH ANNIVERSARY OF BULGARIAN POST - Portrait of the first Bulgarian posts manager - postman on bicycle	1→MS(1)	78-08, {§}
CAYMAN ISLANDS	3.10.14	St	20 c	COMMONWEALTH GAMES GLASGOW / Cyclist - scottish flag	7→7Pn(?) + Bk(10)	79-07, {§}
* CHAD	30.9.13			CYCLING - Eddy Merckx / Fausto Coppi	2→2MS& 2MS(2)	78-08, {§}
COOK ISLANDS	23.6.14	St	4,10 \$	COOK ISLANDS TOURISM PART 2 / Stylized cyclist with woman sitting on the handlebar	12→3SeT(4)	79-07, {§}
		SeT	4 x 4,10 \$	- - - / Se Tenant of 4 diff. Incl. The above		
COSTA RICA	11.12.14	St	500 col	50TH ANNIVERSARY OF VUELTA CICLISTICA A COSTA RICA / Peloton	1→MS(2+t)	79-07
		MS	2 x 500 col	- - - / Miniature Sheet with 2 of the above stamp - tab with José Luis Sanchez, first winner of the vuelta - part of wheel in margin		79-07
FINLAND	23.10.14	St	1 lk	CHANGES IN EVERYDAY LIFE / Vehicles in hexagons - one with a bicycle	6→Bk(6)	79-07, {§}
		Bk	6 x 1 lk	- - - / Booklet of 6 diff. Incl. The above stamp		79-07, {§}
FRANCE	3.5.14	St	LV 20g	Supplement to BS78 (same booklet): HOLIDAY / Snail with caravan - bicycle on back carrier	12→Bk(12)	79-07, {§}
		St	LV 20g	- - - / 2 frogs on a swan like pedal boat		79-07, {§}
	15.9.14	Bk	12 x LV 20g	MARIANNE ET LA JEUNESSE / Booklet with 12 "lettre verte 20g" Marianne definitive stamps - postwoman on bicycle on cover	12→Bk(12)	79-07, {§}
	24.10.14	St	LV 20g	GREETING STAMPS: CHRISTMAS AND NEW YEAR / Bon Voyage! - combined vehicle: plane, van, sailing ship, bicycle on back carrier	12→Bk(12)	79-08, {§}
FRENCH POLYNESIA	12.12.13	St	100 F	VINTAGE CARS / Citroen traction avant (1950) - bicycles behind the car	2→2Shl(10)	79-08, {§}, [PF035.13]
		Shl	10 x 100F	- - - / Sheetlet with 10 of the above stamp and same design in light colours in margin		79-08
GUINEA	20.10.14	St	15000 Fr	ARTISTS / Henri de Toulouse-Lautrec - "La Chaine Simpson" - publicity poster from the 1890s, Constant Huret riding with a Simpson chain behind the Gladiator tandem pacer at the Velodrome de la Seine	28→7MS(4)+ 7→7MS(1)	79-08
		MS	div.	- - - / MS of 4 diff. Incl. the above - no bike motif in margin		
ICELAND	19.2.15	St	B50g innlandands	125 YEARS OF BICYCLES IN ICELAND / Circular stamp as rear wheel with part of bicycle frame and brake - bike trail and race bike in background (B50g innanlands = domestic non-priority mail, at time of issue 125 ISK)	1→Shl(10)	79-14
		Shl	10 x B50g	- - - / Sheetlet of 10 with race cyclists in margin		79-14
INDIA	27.8.14	PS	25 p	ENERGY CONSERVATION / Meghdoot Post Card Released by PCRA Petroleum Conservation Research Association in Tamil language - bicycle in a circle	1	79-08
INDONESIA	27.9.14	St	10000 R	POSTAL SERVICE / Postman with bicycle (Indonesian Post's Issue Program 2014 dates the issue on 26.8.)	2→2Pn(20)	79-08
		Pn	20 x 10000 R	- - - / Pane of 20 of the above - postman with bicycle coarsely rasterized in right margin		79-08
		St	20000 R	- - - / Post Office in Jakarta (Batavia) - trishaws and bicycles in front of building (Photo from Tassilo Adam (1878-1955))		79-09

		Pn	20 x 20000 R	- - / Pane of 20 of the above - postman with bicycle coarsely rasterized in right margin			
* ISLE OF MAN	5.7.14			LE GRAND DEPART YORKSHIRE – THE ROAD TO PARIS / Correction of issuing date	8→8Pn(25)&6MS(2+2t)&6PS	78-09, {§}	
ISRAEL	9.9.14	Shl	10 x 4,50 NIS	TEL AVIV - GLOBAL CITY / Stamps of no cycling interest - 11 cyclists in margin	1→Shl(10)	79-09, {§}	
JAPAN	26.6.14	St	¥ 52	GREETINGS-SUMMER 2014 / HELLO KITTY riding the tricycle	20→	79-09, {§}	
		CShl	10 x ¥ 52	- - / Selvhesive CShl of 10 diff., incl. the above	2CShl(10)	79-09, {§}	
KOREA (NORTH)	29.5.14	St	30 w	140TH ANNIVERSARY OF UPU / Postwoman with bicycle delivers letters	1	79-09, {§}	
	25.7.14	BkP		SPORTS / Booklet Pane of 4 stamps of no cycling interest - cycling pictogram in margin	4→4MS(3+t)+Bk(4)+3PS	79-09, {§}	
		Bk		- - / Booklet with the pane above		79-09, {§}	
		St	30 w		CYCLING SPORTS / Track Cycling	4→Bk(4)+3PS	79-10
		St	50 w		- - / BMX		79-10
		St	70 w		- - / BMX		79-10
		St	110 w		- - / Road Cycling		79-10
		BkP			- - / Booklet Pane with the 4 stamps above - text "Cycling Sports" in margin		79-10
		Bk			- - / Booklet with the pane above - Road cyclists on cover		79-10
		PS	30 w		- - / Postal stationary post card with imprinted stamp "Track Cycling" - BMX Riders in sprint on front		79-10
PS		50 w		- - / Postal stationary envelope with imprinted stamp "BMX" - stylized track cyclists on front		79-10	
PS	110 w		- - / Postal stationary aerogram with imprinted stamp "Road Cycling" - track cyclist on front		79-10		
MACAO	12.11.14	St	2 Pat.	MACAO SEEN BY KAM CHEONG LING / Historical painting of Macao - bicycle and rikshaw on street	4→Shl(4x4)+1→MS(1)	79-10, [MO050.14]	
		CPn		- - / Composite Pane of 4 x 4 diff. Incl. the above - trishaw in margin		79-10	
MALDIVE ISLANDS	7.10.14	St	RF22	17TH ASIAN GAMES 2014 INCHEON, KOREA / Stylized cyclist	4→MS(4)+	79-10	
		St	4 x RF22	- - / MS of 4 diff. Incl. the above - no bike motif in margin	1→MS(1)	79-10	
MEXICO	14.5.14	St	7 \$	40TH ANNIVERSARY OF FONACOT (INSTITUTO DEL FONDO NACIONAL PARA EL CONSUMO DE LOS TRABAJADORES) / Silhouette of child on bicycle	1	79-10, {§}	
MONACO	1.9.14	St	0,59 €	25TH ANNIVERSARY OF SPORTEL / different sports - cycling	1→Shl(10)	79-10, {§}	
NETHERLANDS	2.8.14	St	①	12,5 YEARS OF ROYAL MARRIAGE / Willem-Alexander and Máxima with their three children on bicycles	5→CShl(10)	79-11, {§}	
		CShl	10 x ①	- - / Composite Sheetlet of 2 x 5 diff. Incl. the above - diff. Se-Tenants possible		79-11, {§}	
OMAN	14.8.14	St	250 B	TOUR OF OMAN / Peloton	1→MS(1)+PS	79-11	
		MS	250 B	- - / MS of the stamp above - waterfront of Muscat in margin		79-11	
		PS	250 B	- - / PS with imprinted stamp above and peloton on front side		79-11	
PALAU	23.4.14	St	2,50 \$	100TH ANNIVERSARY OF WORLD WAR I / British Army recruits in training - bicycles	4→MS(4)+1→MS(1)	79-11	
		MS	4 x 2,50 \$	- - / MS of 4 diff. Incl. the above - no bike motif in margin		79-11	
POLAND	11.07.14	St	3,75 zł	THE HISTORY OF POLISH PHOTOGRAPHY - HENRYK PODDEBSKI (1890-1945) / Streetscene in Królewska Huta - cyclist on the street	4→CPn(3x4)	79-11, {§}	
		SeT		- - / Se-Tenant of 4 diff. Incl. the above		{§}	
		CPn		- - / Composite Pnae of 3 x 4 diff. Incl. the above		{§}	
PORTUGAL	27.1.15	St	0,42 €	SUSTAINABLE MOBILITY / Diff. Vehicles - road sign with bicycle	2→Shl(2x10)	79-12, {§}	
		St	0,80 €	- - / 2 cyclists on bike path - cycling pictogram on road surface		79-12, {§}	
		SeT	0.42/0.80 €	- - / Se-Tenant of 2 diff. Incl. the above			
* SINGAPORE	13.7.13	St	80 c	OUR CITY IN A GARDEN / Correction of issuing date	4→4Shl(10)&MS(2x2)+1→MS(1)	76-15, {§}	
SINGAPORE	28.5.14	St	2 \$	DEFINITIVES: PAST STREET SCENES / Trishaw in front of trolleybus (Offset lithography with ink that changes colours in sunlight)	4→4Shl(10)	79-12, {§}	
		St	5 \$	- - / Chinese Street Opera or Wayang - food both: seems to be a mobile bike shop - a wheel under a pot or basket		79-12, {§}	
	18.7.14	St	80 c	ISLANDS OF SINGAPORE - PULAU UBIN / Wayang Stage - boy on bicycle in audience	4→4Shl(10)	79-12, {§}	

	4.8.14	St	1st Local	49 YEARS OF INDEPENDENCE - I AM SINGAPOREAN / P - Park Connector Network - 2 cyclists ("Singapore has been championing the clean and green cause before being environmentally friendly became popular. Today, we have an intricate network of green corridors and biking routes that we are proud of.")	15→CPn(15)	79-12, {S}
		CPn	15 x 1st Local	-- / Composite Pane of 15 diff. Incl. the above building the phrase "I am Singaporean" - no bike motif in margin		79-12, {S}
	31.10.14	St	2nd LOCAL	50 YEARS OF TOURISM IN SINGAPORE / 3 cyclists and joggers on trail - buildings in background	5→5Shl(10)	79-12, {S}
		St	90 c	-- / Rickshaw with tourists		79-12, {S}
	26.11.14	St	1,15 \$	DEFINITIVES: PAST STREET SCENES II / Riverside scene - cyclist (Offset lithography with ink that changes colours in sunlight)	2→2Pn(10)	79-12, {S}
		CShl		DEFINITIVES: PAST STREET SCENES COLLECTOR SHEET / Composite Sheetlet of all 6 stamps incl. the 3 bike stamps - no bike motif in margin (Sold at 28 \$)	6→CShl(6)	79-12, {S}
		CPn		DEFINITIVES: VANISHING TRADES COLLECTOR SHEET / Composite Pane of 10 reissues of 2013 incl. Dairy Man (BS 77-17) and 4 new stamps (Reissues have imprinted year and index e.g. 2013B, 2014C etc. Sold at 12,80 \$)	14→CPn(14)	79-12, {S}
* SLOVENIA	22.3.13			EUROPE 2013 - POSTAL VEHICLES / Correction of issuing date	2→2Shl(8+T)	75-14, {S}, [SI013.13]
SOLOMON ISLANDS	20.11.14	St	\$ 7	GLASGOW 2014 COMMONWEALTH GAMES / Triathlon - man cycling with triathlon bike	4→MS(4)+1→MS(1)	79-13
		MS	4 x \$ 7	-- / Miniature Sheet of 4 diff. Incl. the above - no bike motif in margin		79-13
SPAIN	3.1.14	St	0,54 €	60 YEARS EUROPEAN ORGANISATION FOR NUCLEAR RESEARCH (CERN) / Female Scientist on bicycle in underground plant	3→3Pn(25)	79-13, {S}
	21.9.14	PS	B	UCI ROAD WORLD CHAMPIONSHIPS PONTFERRADA / Imprinted stamp of no cycling interest - stylized cyclist on front side	1	79-13
ST. THOMAS AND PRINCE ISLANDS	15.9.14	MS	3 x 25000 Dbs	ELECTRIC TRANSPORT / Stamps of no cycling interest - pedelecs at charging station in margin	4→MS(4)+1→MS(1)	79-13
THAILAND	9.10.14	St	3 THB	WORLD POST DAY / People on earth - cyclist (Maybe it's a motor cycle)	1→Shl(10)	79-13, {S}
	10.1.15	St	3 THB	NATIONAL CHILDREN'S DAY / Boat and trishaw	5→CShl(2x5)	79-13, {S}
		St	3 THB	-- / trishaw and auto trishaw		79-13, {S}
		St	3 THB	-- / 2 trishaws		79-13, {S}
		St	3 THB	-- / Bus and trishaw		79-13, {S}
		St	3 THB	-- / trishaw and auto trishaw		79-13, {S}
		CShl	10 x 3 THB	-- / Composite Sheetlet of 2 x the above 5 stamps - no bike motif in margin		79-13, {S}
TOGO	30.10.14	MS	2500 F	ASIAN GAMES / MS of 1 - stamp of no cycling interest - stylized BMX rider in margin	4→MS(4)+1→MS(1)	79-14
		St	750 F	ELECTRIC TRANSPORT / The Solar Impulse, a Swedish aircraft powered by solar energy - cyclist in front of it		79-14
		MS	4 x 750 F	-- / MS of 4 diff. Incl. the above - no bike motif in margin		79-14
TRISTAN DE CUNHA	28.10.14	St	60 p	350TH ANNIVERSARY OF ROYAL MARINES / 1944 Normandie Invasion - soldier unloads a bicycle from vessel	6→6Shl(10)	79-14, {S}
UKRAINE	31.10.14	St	2,00 ₴	125 YEARS POST OFFICE OF CZERNOWITZ / Post Office of Czernowitz - child on tricycle on street	1→Shl(8)	79-14, {S}

### Locals

GERMANY <sup>2</sup>						
BRIEF UND MEHR (MÜNSTER)	01.08.14	St	55 c	725 YEARS CITY OF HALTERN / The old Townhall - bicycles standing under the arcades	1→Shl(10)	79-15
CITIPOST OWL (CITY BIELEFELD)	? .12.14	St	Standardbrief	CHRISTMAS / Father Christmas on child's bicycle	1→Shl(10)	79-15
DEREILBOTE (THURINGIA)	06.11.14	St	49 c	25 YEARS "WELTSICHTEN" AXEL BRÜMMER & PETER GLÖCKNER / On cyclingtour around the world 1990 - both on bicycle	1→Shl(10)	79-15
		St	49 c	-- / On cyclingtour around the world 1994 - one on bicycle in USA		79-15
		St	49 c	-- / cyclingtour Marco Polo 2001 - portrait of both with bicycle		79-15
		St	49 c	-- / 2013 - portrait of both with bicycle		79-15
		CShl	10 x 49 c	-- / Composite Sheetlet of 10 diff. Incl. the 4 above - map with routes in margin		79-15
		St	49 c	17TH SLIDE SHOW FESTIVAL THURINGA 2015 / Logo of Weltsichten.de - 2 cyclist on surface of a globe		79-15

		CSHl	10 x 49 c	- - - / Composite Sheetlet of 10 diff. Incl. the above - map with routes in margin		79-15
EXPRESS BRIEF KURIER (CITY JESSEN) (FORMER EXPRESS SCHATZTRUHE)	10.10.13	St	40 c	ARTISTIC CYCLING IN ANNABERG / Richard Steyer (1905)	5→CPn(10x5)	79-15, {§}
		St	50 c	ARTISTIC CYCLING IN ANNABERG / Club: Anaburger Hallenrad-SV e.V.		79-15, {§}
		St	85 c	ARTISTIC CYCLING IN ANNABERG / 1 artistic cyclist		79-15, {§}
		St	1,30 €	ARTISTIC CYCLING IN ANNABERG / 3 artistic cyclists		79-15, {§}
		St	2,00 €	ARTISTIC CYCLING IN ANNABERG / 1 artistic cyclist - Steuerrohrsteiger a artistic figure		79-15, {§}
		Set	0	- - - / Se Tenant of the 5 stamps above		79-15, {§}
LVZ POST	27.4.14	PS	42 c	LVZ FAHRRADFEST 2014 / Card with imprinted stamp "LVZ-Fahrradfest 27. April 2014" and 3 stylized cyclists - photo of woman on bicycle and 3 stylized cyclists on backside	5→CPn(10x5)	79-16, {§}
		St	50 c	60 YEARS TOP-CLASS SPORT IN LEIPZIG / Jens Lehmann - winner of olympic gold medal 1992		79-16
	MS	6 x 50 c	- - - / MS of 6 diff. Incl. the above - further names in margin e.g. Judith Arndt, Uwe Raab, Gustav Adolf Schur, Erich Hagen, Egon Adler, Bernhard Eckstein	79-16		
MAILCATS (THURINGIA, CITY BIKE COURIER)	16.6.12	PS	0,39 €	20 YEARS PRIVATE POST / Motif of stamp from 12.3.12 (BS74) on front side - photo of 3 bike couriers on backside	1	79-16, {§}
MORGENPOST (CITY MANNHEIM)	17.7.14	St	158 c	POSTWOMAN / Postwoman with bicycle assorting letters	1→Shl(10)	79-xx
	15.8.14	St	230 c	POSTWOMAN / Postwoman with bicycle assorting letters - same motif as 17.1.2014 with new value	1→Shl(10)	79-xx

<sup>1</sup> More information about the efforts of Australia Post to outstrip Stamperija's methods of rip-off you can find on the ASV Website <http://www.asv.net.au> from David Mallen especially in "Australian Impressions", "Collectable Stamps of Australia" or the "Australian Stamp Variations Catalogue"

<sup>2</sup> Michel decided not to continue cataloguing "Modern German Private Post". So known Catalogue numbers (§) are depending on "Merkur-Briefe", magazine of the study group "Privatpost-Merkur im BDPH e.V." (<http://www.privatpost-merkur.de/>)

Key:

1. Undated issues will remain on this list or the "Issue Information Update" list, until such time as a date of issue is established.
2. Abbreviations:  
NIA = No Image Available  
- - - = As above (ditto mark)  
SeT = Se Tenant, S? = Strip of ? stamps, Sh = Sheet, Pn = Pane, C = Coil, Shl = Sheetlet, MS = Miniature Sheet, CPn = Composite Pane, CSHl = Composite Sheetlet, Bk = Booklet, BkP = Booklet Pane, PBK = Prestige Booklet, Coll = Collection, PS = Postal Stationary, FDC = First Day Cover, MC = Maximum Card  
Definitions according to MICHEL and "PHILATELIC TERMS ILLUSTRATED", James MacKay, Stanley Gibbons 2003 ([!] partly contrary to LINN'S).  
For Perforations the TCTC notation of Doug Myall (Complete Deegam Machin Handbook) is used with "T" being "torn" and "C" being "cut" in the order: top, right side, bottom and left side. (e.g.  $\overline{\text{TTCT}}$ )
3. Issues marked \* have been corrected or have additional information. The additional or corrected information is underlined.
4. Issues marked  $\square$  are deemed to be fake, i.e. not stamps only Cinderellas or illegals, therefore they will not have a date of issue (Cinderellas are fantasy products. Illegals are unauthorized stamps sometimes with the name of real existing postal authorities produced in fraudulent intent).
5. Additions to the list are indicated by a heavy solid left-hand border to the country's name box. Additions that are not really new, but not mentioned in one of the known Bicycle Stamp catalogues (Batho, Hilarides, Malone, Muhsil, Waltl) marked with a white  $\square$  in the border.
6. Issues that appear on this list for over a year are moved to the "Issue Information Update" list.
7. Content of set: Meaning of signs and abbreviations  
"→" = published in ... (ex. 2→2Shl(10) = 2 stamps published in 2 sheetlets of 10 each)
8. The last column shows where the stamp is illustrated, with BS number, followed by page number.
9. If any catalogue entry (Scott, Stanley Gibbons, Michel or Yvert & Tellier) or information from postal authority or official agency is known it is indicated with "{§}" in the same column. If a WNS no. is known it is stated (e.g. "[LR024.09]"). The WNS no. documents, that it is definitely a legal issue.  
For WADP Numbering System (WNS) (see → <http://www.wnsstamps.ch/en/about>).
10. Personalized stamps are only listed if they are published by postal administrations or well-known organizations.

Many thanks to Piet Hein Hilarides for his valuable information from his catalogue updates.

(Please note that the images are not true to scale)



ANDORRA (SPANISH)  
21.2.13



Argentina  
27.4.13



Cook  
Islands  
23.6.14



Cayman  
Islands  
3.10.14

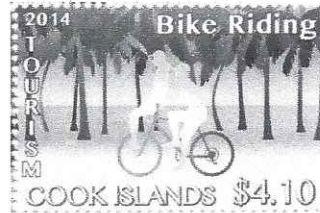

Finland  
23.10.14



Costa  
Rica  
11.12.14

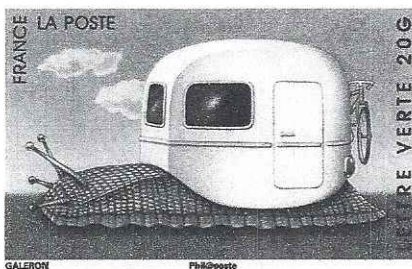
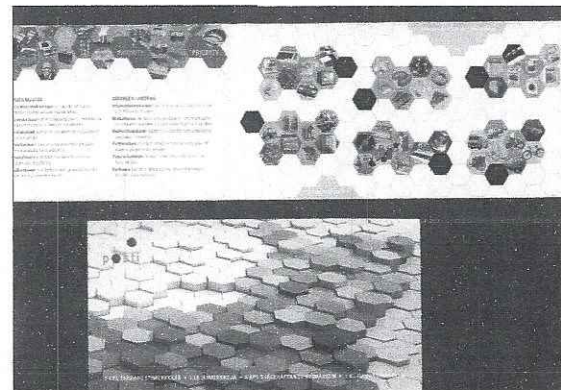

France  
3.5.14

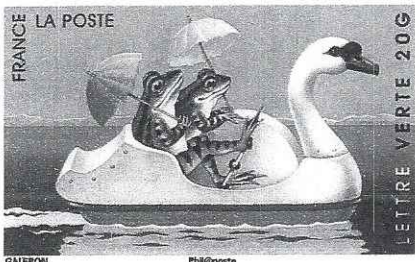

France  
15.9.14



France  
24.10.14



French  
Polynesia  
12.12.13



Guinea  
20.10.14



India  
27.8.14

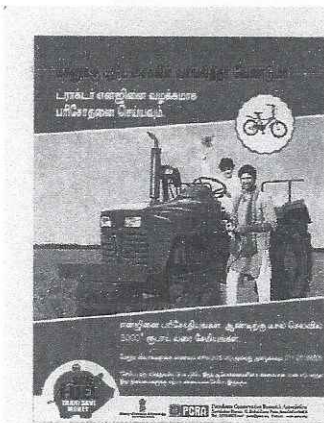

Indonesia  
27.9.14







Foto →  
Album,  
sonst ist  
das Foto  
nach nicht  
sichtbar

Israel  
9.9.14

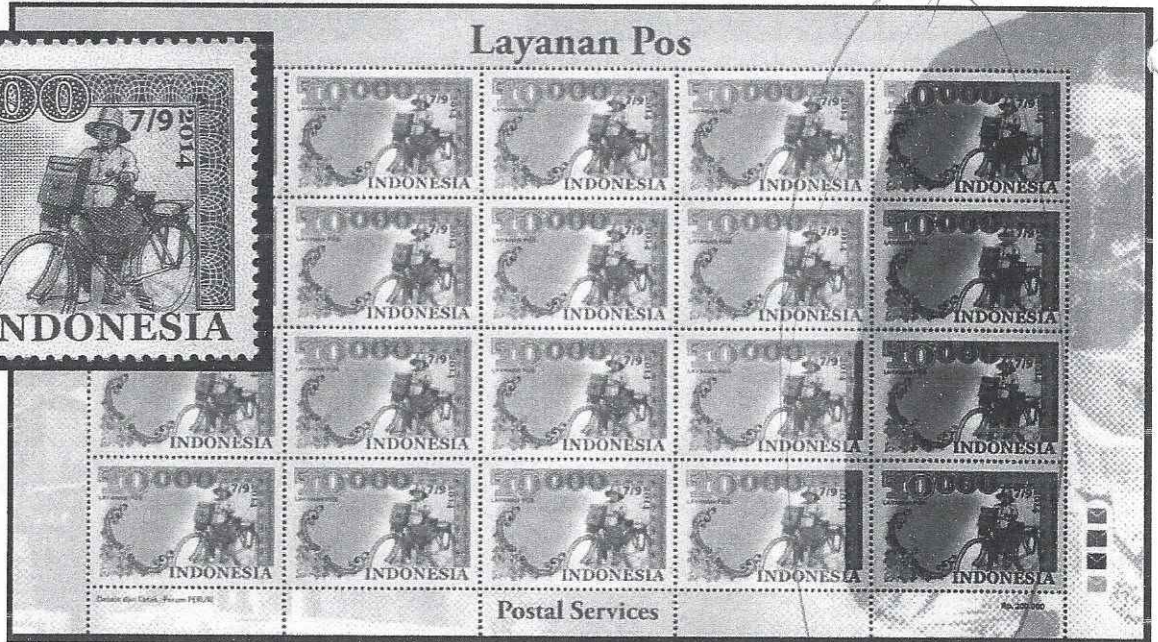
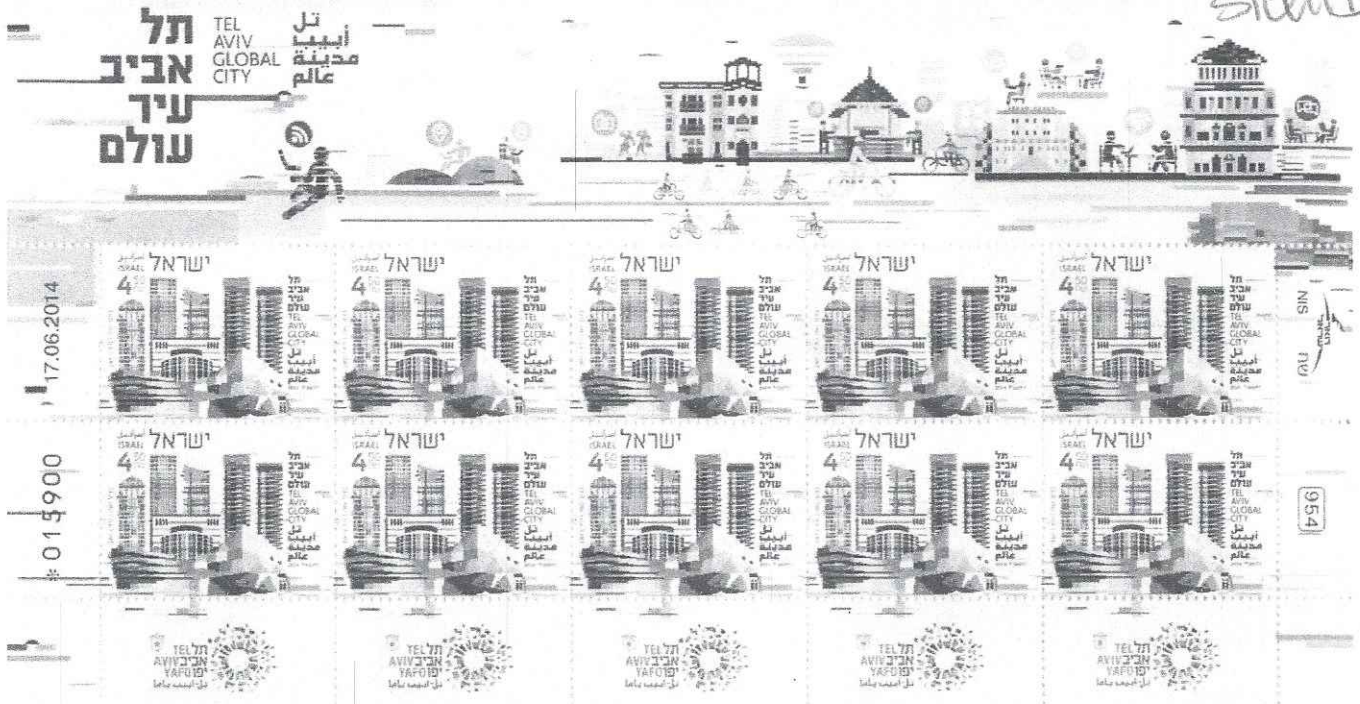

Japan  
26.6.14

Korea North  
29.5.14



Korea North  
25.7.14

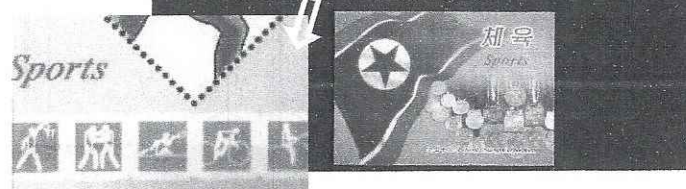

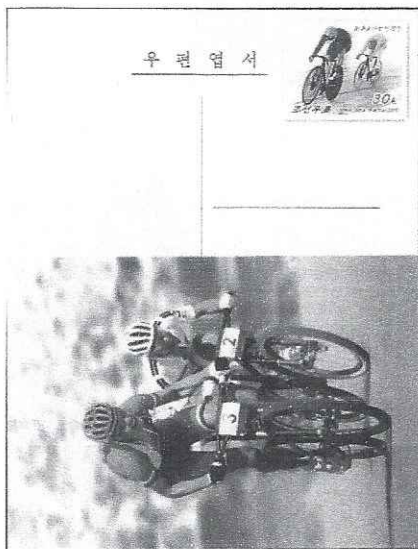

Korea  
North  
25.1.15

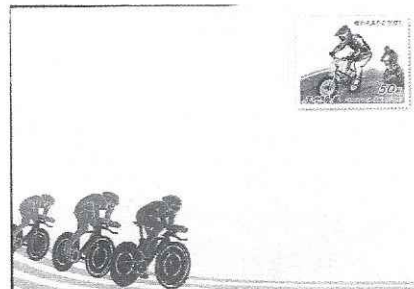

Macao  
12.11.14



Maldives  
12.11.14



Mexico  
14.5.14



Monaco  
1.9.14



17th Asian Games 2014 Incheon, Korea





Netherlands  
2.8.14

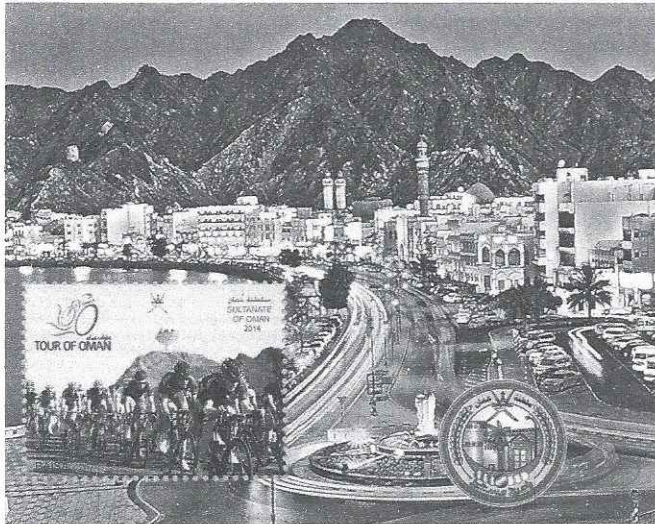

Oman  
14.8.14



Poland  
14.8.14

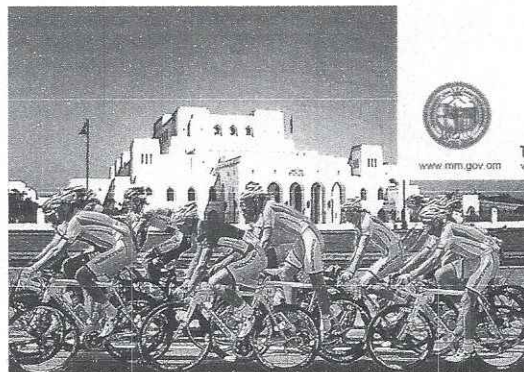

عمان  
Oman Post  
2014 www.omanpost.om  
POSTAGE PREPAID TO ANYWHERE IN THE WORLD



Palau  
23.4.14





Portugal  
27.1.15



Singapore  
18.7.14



Singapore  
28.5.14

Singapore  
4.8.14

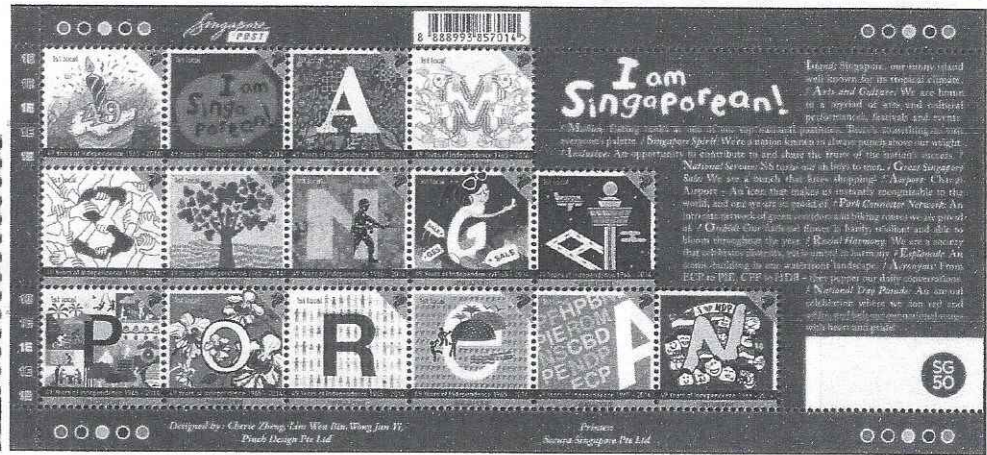

Singapore  
31.10.14



Singapore  
26.11.14

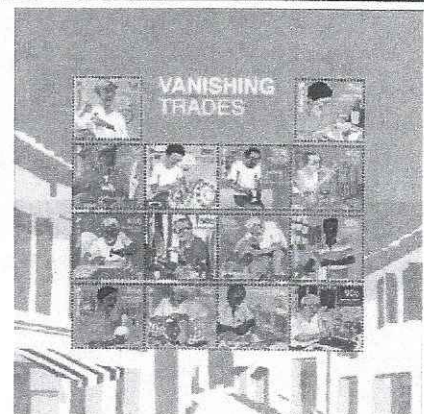
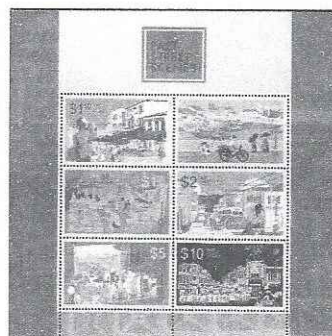



Solomon  
Islands  
20.11.14



Spain  
3.1.14



Spain  
21.9.14



St. Thomas  
And Prince  
Islands  
15.9.14

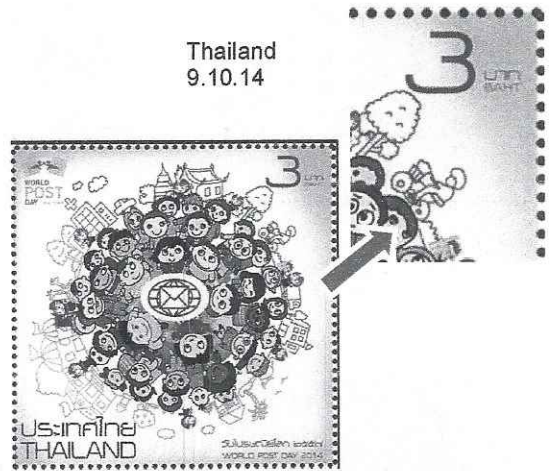

Thailand  
9.10.14



Thailand  
10.1.15



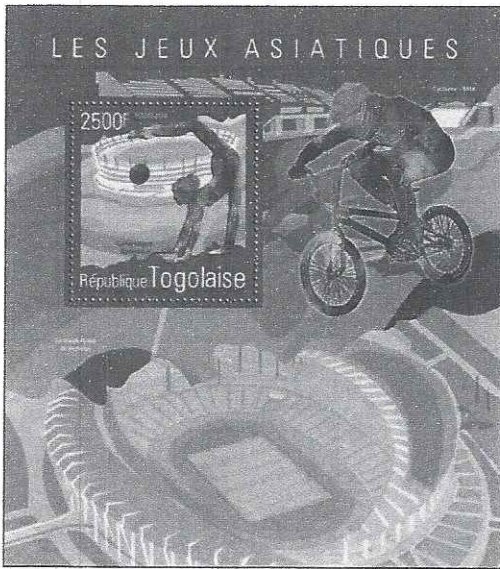

Togo  
30.10.14

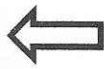
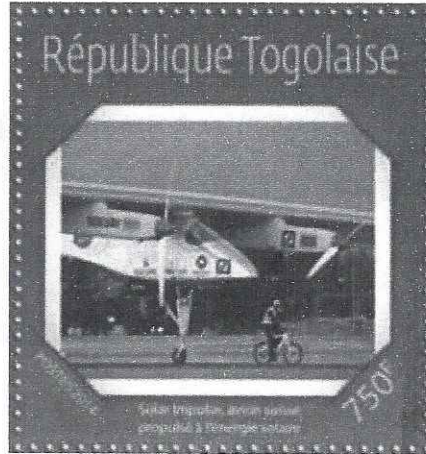

Tristan de  
Cunha  
28.10.14



Ukraine  
31.10.14



Iceland  
19.2.15



*Harley-ni 100€!*

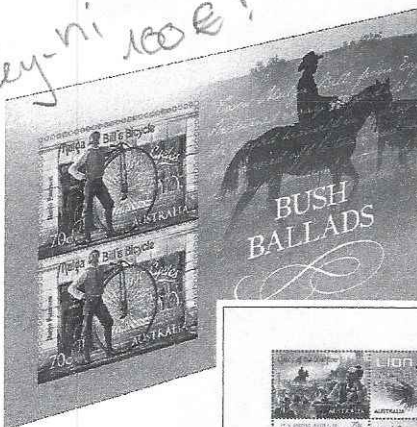

Australia  
7.11.14

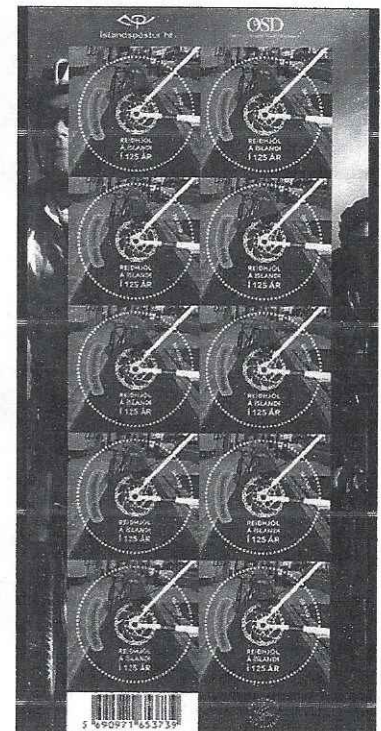
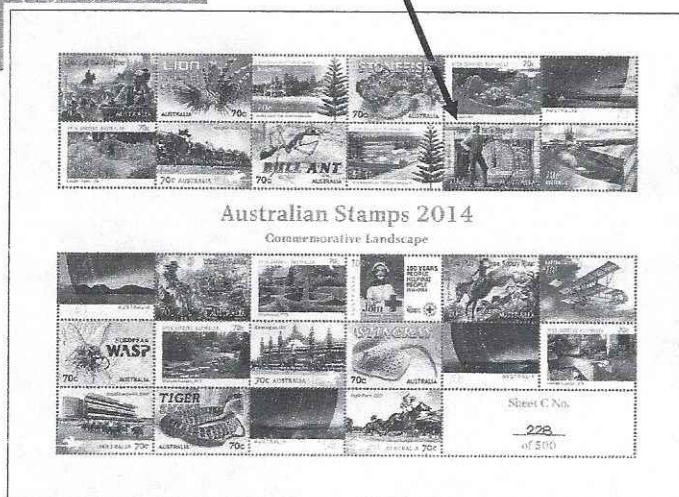

# LOCAL STAMPS

Germany

Brief und mehr  
1.8.14

CITIPOST OWL  
7.12.14

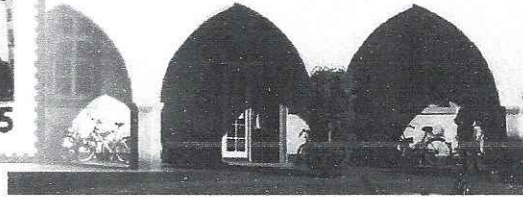

Express Brief Kurier  
10.10.13



*25 Jahre Freiheit und Abenteuer - Axel Brühmer und Peter Glöckner*

1990



weltsichten.de

Rüdiger Nebberg: „WELTSICHTig über den Tellerrand schauen...“



DerEilbote  
6.11.14







**CARBON FIBRE £1.28 STAMP ISSUED BY ROYAL MAIL 19 February 2015**



In 1963, William Watt and colleagues Leslie Phillips and William Johnson were responsible for the invention of carbon fibre at the Royal Aircraft Establishment. It has greater strength and resistance to heat corrosion and damage compared to plastic. They devised a process that would line up millions of carbon molecules in the same orientation in a fibre, so that it could be handled as easily as plastic. The LOTUS 108 PURSUIT BICYCLE was the first to use carbon fibre moulded into a monocoque frame.

In 1992 CHRIS BOARDMAN won an Olympic Gold medal on a pioneering bike with a monocoque frame moulded primarily from carbon fibre.

ABOVE: Enlarged copy of the £1.28 stamp.

BELOW: Extracts from the Royal Mail Prestige Stamp Book, "Inventive Britain".

*essentially not in prestige booklet*

**Carbon Fibre**



**Above**  
William Watt, who led the team responsible for the invention of carbon fibre, had a successful 39-year career at the Royal Aircraft Establishment.

**Right**  
Designed by Mike Burrows, the Lotus 108 Pursuit bicycle was the first to use carbon fibre moulded into a monocoque frame.

**1944**  
William Watt joins the Royal Aircraft Establishment as part of a group researching high-temperature non-metallic materials.

**Inventive Britain**

plastic. The technique employed by the RAE involved combining carbon fibres with a polymer called polyacrylonitrile (also known as PAN) and heating it in several stages. The material the process created was strong and very light, and crucially its fibres could be moulded to make versatile composites resistant to heat and tearing, as well as corrosion-proof.

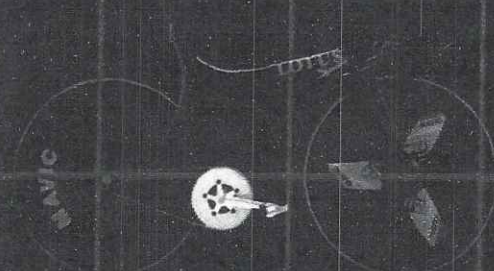

**1963**  
After the breakthrough made by Watt and his team, the UK Ministry of Defence patents a system for manufacturing carbon fibre.



## FRESNO AND SAN FRANCISCO BICYCLE MAIL 1894

Workers of the Pullman Company in Chicago called a strike after their wages were reduced on 11 May 1894. The American Railway Union supported the strikers and ordered a boycott of all Pullman cars on 26 June 1894. The railroads refused to operate any trains that had Pullman cars assigned to them. As a result all rail traffic in the San Joaquin Valley of California came to a halt. All towns were isolated from San Francisco. It was Arthur C Banta, owner of the Victor Cyclery shop in Fresno who seized the opportunity to organise a cycle mail service between Fresno and San Francisco, during the strike.

Around 1 July Arthur Banta began organising the mail route, printing flyers and recruiting cyclists. Banta represented the Overman Wheel Co. agency in Fresno and made arrangements for mail deliveries and pickups at the Overman agencies in San Jose and San Francisco. On 6 July, an engraver in Fresno, Eugene Donze, suggested to Banta that a stamp be printed for this service and he prepared a die that day. The stamps were printed in green in blocks of 6 in 2 rows of 3 stamps, which were rouletted. The Fresno postmaster became aware of this private mail service, which could have violated postal regulations. However, Banta ensured that each envelope carried was franked with the appropriate U.S. postage plus one of his 25c diamond shaped green stamps and handed in at the nearest post office that could deliver the item. In addition he purchased some postal stationery envelopes, with an imprint of a 2 cents U.S. stamp, on which the engraver printed the cycle stamp, but in brown.

The service commenced at 4.30am on 7 July with a cyclist carrying 15 letters, without the cycle stamp, on the first leg of the 210-mile journey to San Francisco. A further 10 letters were picked up en route. The first printing consisted of 816 stamps, delivered on the day after the first mail cycle run. An astute stamp collector in Fresno quickly spotted a spelling error on the stamps, "Francisco" had been spelt "Fransisco". The engraver touched up the die making the first 's' look like a 'c'. However, by careful comparison between the first 816 stamps and the second issue of about 1,000 stamps, it can be seen that the engraver created a new die, but incorporated the large 'c', as if he had amended the first die. The earliest recorded date stamp on a cover is July 11, 1894, on a stamp from the original printing.

On 15 July 1894, federal troops ended the railway strike and the regular mail service slowly returned to normal. The last official bicycle mail left Fresno on 16 July 1894 and was delivered by the relay of cyclists in San Francisco on 18 July. On 17 July and 19 July some additional mail was sent from Fresno to San Francisco but this was entirely philatelic mail. In August 1894 Donze engraved a new die, which he defaced with one horizontal line and five vertical lines, claiming that the original die had been destroyed but this was untrue. In 1935 Banta organised a memorial rerun of the bicycle mail service and had about 2,000 stamps printed for an enactment on 1 May.

The full story of this unusual cycle mail service is recounted in Lowell B. Cooper's book, entitled *The Fresno and San Francisco Bicycle Mail of 1894*, published by Leonard H Hartmann in 1982.

Brian Sole  
February 2015

# FRESNO AND SAN FRANCISCO BICYCLE MAIL 1894



First die and incorrect spelling of SAN FRANSISCO.



A modern re-print with the correct spelling.

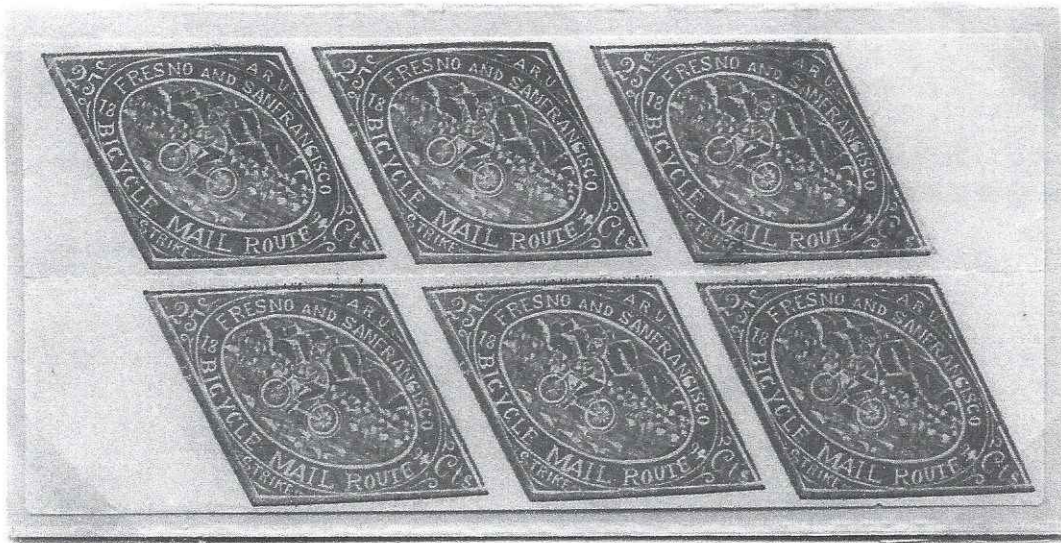

Block of 6 stamps with correct spelling of SAN FRANCISCO but imperforate vertically.

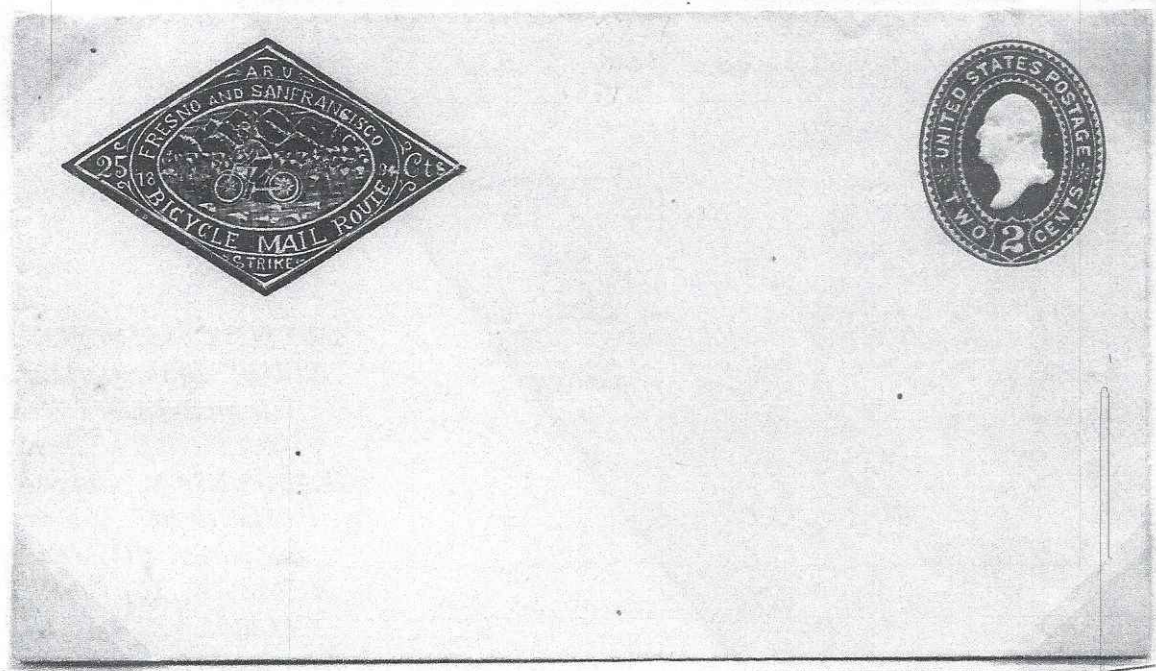

Official US postal stationery envelope with a brown imprint of the SAN FRANCISCO stamp.

CYCLISTS' TOURING CLUB



CYCLISTS' TOURING CLUB.



RENEWAL NUMBER  
SEE SPECIAL FORM ATTACHED

*the Gables  
Dennis Parris  
Glamorgan*

47, VICTORIA ST., WESTMINSTER, LONDON, S.W.

Founded 1878.

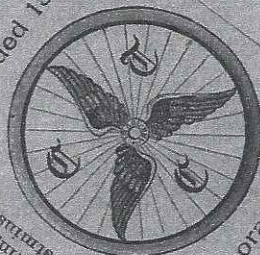

Incorporated 1887.

In case of non-delivery, to be returned to the  
Cyclists' Touring Club,  
47, Victoria Street, Westminster, London, S.W.



1897 "CYCLISTS' TOURING CLUB". Illustrated wrapper from BRADFORD, YORKSHIRE addressed to GLAMORGAN... handstamped "PAID" in red. The wrapper contained "RENEWAL NUMBER... SEE SPECIAL FORM ATTACHED". Accompanied with a block of four of the "C.T.C." Jubilee stamps produced by Perkins Bacon in 1928. Super cover and very scarce.

An Edinburgh medical student, Stanley Cotterell, founded the Cyclists' Touring Club at Harrogate in Yorkshire on 5 August 1878. It was originally called the Bicycle Touring Club and its headquarters were wherever Cotterell happened to be living. It had 80 members, all men. The first woman to join was Mrs W D Welford, in 1880. The Club was renamed the Cyclists' Touring Club in 1883 to open up membership to tricyclists. Membership rose to 10,627 and the CTC opened a headquarters at 139-140 Fleet Street in London.

The Club's members often rode in uniform, like those from other clubs. The CTC appointed an official tailor to provide members with their uniform. This was a dark green Devonshire serge jacket, knickerbockers and a "Stanley helmet with a small peak". The colour changed to grey when green proved impracticable because it showed the dirt. Groups often rode with a bugler at the head to sound changes of direction or to bring the group to a halt. Confusion could be caused when groups met and mistook each other's signals!

**RIGHT:**

The vignette for the 50<sup>th</sup> anniversary of the CTC was prepared and issued well in advance of the anniversary date of 5 August 1928. See the postmark on the vignette Wolverhampton Staffs, 7 February 1928.

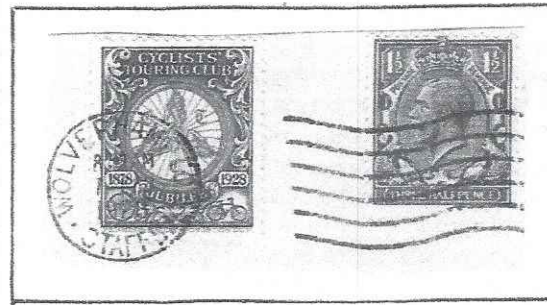

**BELOW:** The CTC advertised 1930 Motorcycle & Cycle Show on back of envelopes.

In case of non-delivery, to be returned to the  
CYCLISTS' TOURING CLUB,  
3, Craven Hill, LONDON, W.2.

*Appointment  
re Council for  
the France trip  
1931.*

A. W. K. Hawking, Esq.,  
90, Hills Road,  
CAMBRIDGE.

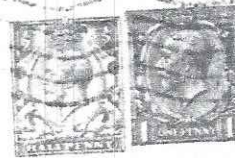



FIGHT FOR FREE CARRIAGE OF BICYCLES ON TRAINS USA 1896  
Submitted by Arnoldt REHM

**MERIDEN DAILY REPUBLICAN, THURSDAY, MAY 14 1896**

are for both gold  
volutions will be  
than the Ohio res-  
r a strong resolu-  
high protective  
materials of the  
ral products of the  
slution for protec-

**SYMPATHY FOR KIPLING.**

**HAS OFFERS OF PROTECTION  
AGAINST HIS BROTHER-IN-LAW.**

Brattleboro, Vt. May 14.—The Kip-  
ling-Balchier case continues the ab-

**MESSAGE AROUND THE WORLD**

**ARRANGEMENTS FOR A TEST OF  
TELEGRAPHY.**

New York, May 14.—The Smithsonian  
Institute has made a request for the

Ive

**BICYCLE BAGGAGE LAW.**

**WHEELMEN WANT NEW YORK  
MEASURE ADOPTED.**

A prominent member of the Rose of  
New England Wheel club, of Norwich  
says that it is the intention of the  
club to send a petition to the next  
general assembly asking for legislation  
similar to that recently passed in Al-  
bany, making bicycles baggage, and  
giving them free carriage on railways  
in this state. One of the greatest  
drawbacks to wheeling, the person  
quoted, said, is that whenever a rider  
wishes to take his wheel by rail he is  
charged a stiff price for it, even though  
he has no other luggage. The rail-  
roads advertise to carry 150 pounds of  
personal baggage free on every first  
class ticket, he said, and yet they bar  
out a bicycle which weighs from 20 to  
30 pounds.

The petitions are already in circula-  
tion, and will be sent to every town in  
the state, so that every wheelman may  
have an opportunity to sign it. It is  
expected that when the document is  
transmitted to the legislature it will be  
a formidable affair, with many thou-  
sand signatures. It was at first in-  
tended to attach another paragraph  
asking for the passage of a law in ef-  
fect like the one now in force in Rhode  
Island, which provides a penalty of \$20  
for knowingly throwing tacks, nails,  
broken glass, or other substances in-  
jurious to bicycle tires into the street,  
but it was finally decided that the pe-  
tition would be more forcible if he one  
and greater boon was asked for only.  
If this is granted it is probable that a  
second prayer may be sent to the as-  
sembly asking the passage of the other  
bill.

This is "bicycle-baggage-law" literature.  
Read it carefully.  
We want your help.



H E Deats 1 Apr 97  
Flemington N J

OFFICE SEC'Y-TREAS., N. J. DIV. L. A. W., TRENTON.

# A POSTMAN USING A BICYCLE SUBJECT TO A 4-YEARLY MEDICAL EXAMINATION

Copies of both sides of a medical form, reduced, postmarked 14 July 1928, at Woking Surrey.

P. 278.  
(Rev. 2022/24)

## CYCLING DUTY.

Date Stamp.



### I.—To be attended to by the Postmaster.

Name Mr R.W. Tronbridge Cycling Duty { Designation  
Length 17 1/2 miles  
Average weight carried 35 lb.  
Nature of route Good  
Weight in lb.  
Date of birth 6.9.87 Height in inches 72  
Is the candidate an ex-navy or ex-army man? Army Is he a practised cyclist? Yes  
Is he performing a cycle duty now? If so, state length of employment on it.  
If any defects of sight or hearing have come to notice, these should be reported to the Medical Officer.

### Particulars of Sick Absences during past 4 years.

Year	19 28.	19 26.	19 27.	19 24.	
No. of days	Cause	No. of days	Cause	No. of days	Cause
	<u>1</u>	<u>1</u>	<u>8</u>		
	<u>flu</u>	<u>flu</u>	<u>Influenza</u>		

When an officer is sent to the Medical Officer for his quadrennial examination, the previous reports should always be forwarded.

The Medical Officer, Mr R.W. Tronbridge has been instructed to call on you for Medical Examination. Your report will, perhaps, be made overleaf.  
Date 14 July 28 Post Office Woking  
Sgd. H.E. Austin Postmaster.

### II.—To be filled in by the Medical Officer.

- (1) Is there any evidence of impaired function or disease of the respiratory system? no
- (2) Is the heart free from all signs of disease? Yes
- (3) Are the arteries free from signs of disease or degeneration? Yes
- (4) Is he free from physical defects or disease rendering him unsuitable for cycling duty? Yes

Signature

H. Arthur Southwell

Date

July 16. 1928.

As regards the *Initial Examination for Cycling duty*, if the candidate has been examined medically on appointment within four years and the records of that examination are completely satisfactory, and if his health in the interim has been good, the Medical Officer may confine his report to an affirmative answer to question 4 without a fresh physical examination.



CYCLE ADVERT 1934 DANISH BOOKLET & NORTH KOREA SLOGANS

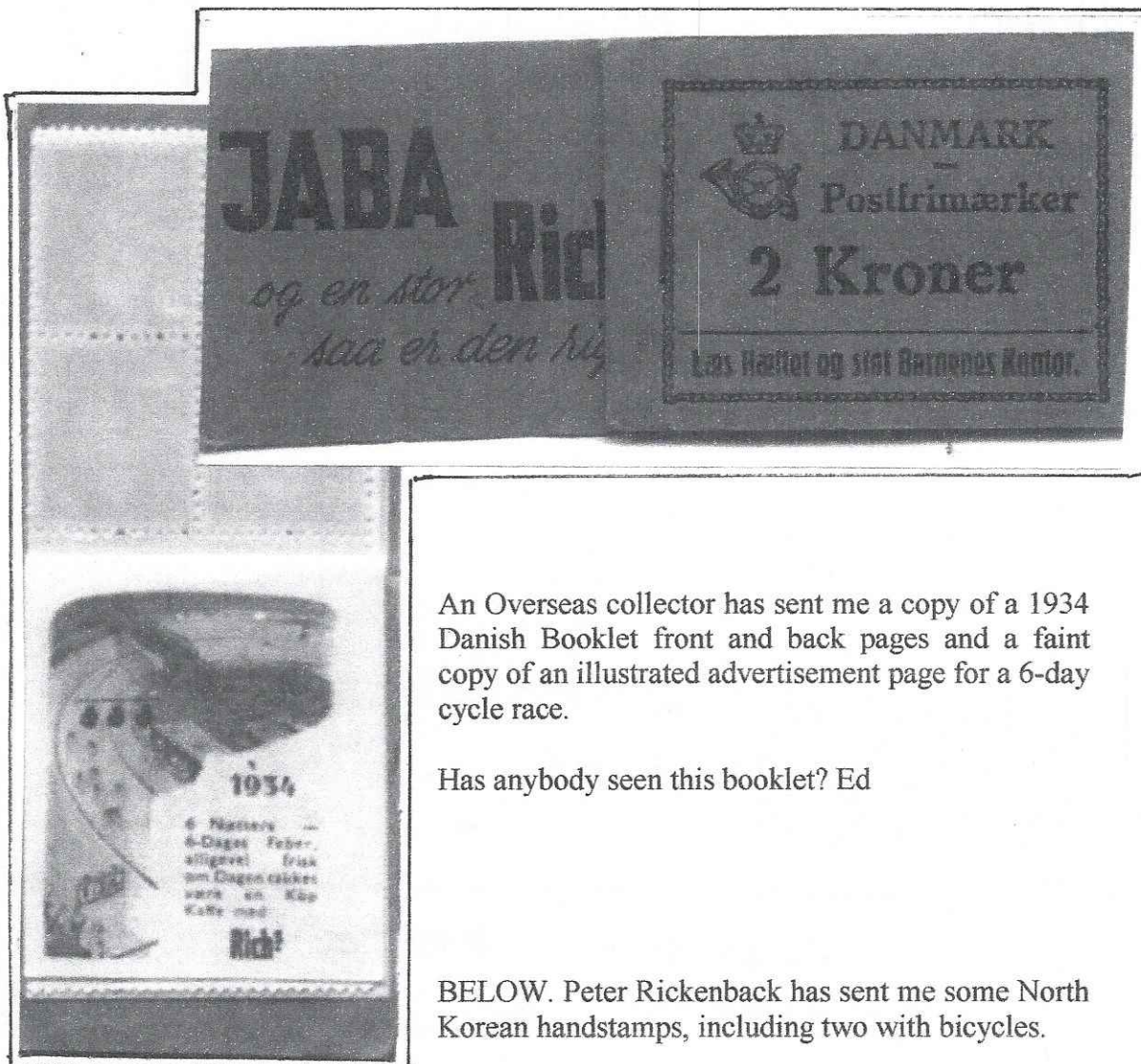

An Overseas collector has sent me a copy of a 1934 Danish Booklet front and back pages and a faint copy of an illustrated advertisement page for a 6-day cycle race.

Has anybody seen this booklet? Ed

BELOW. Peter Rickenback has sent me some North Korean handstamps, including two with bicycles.

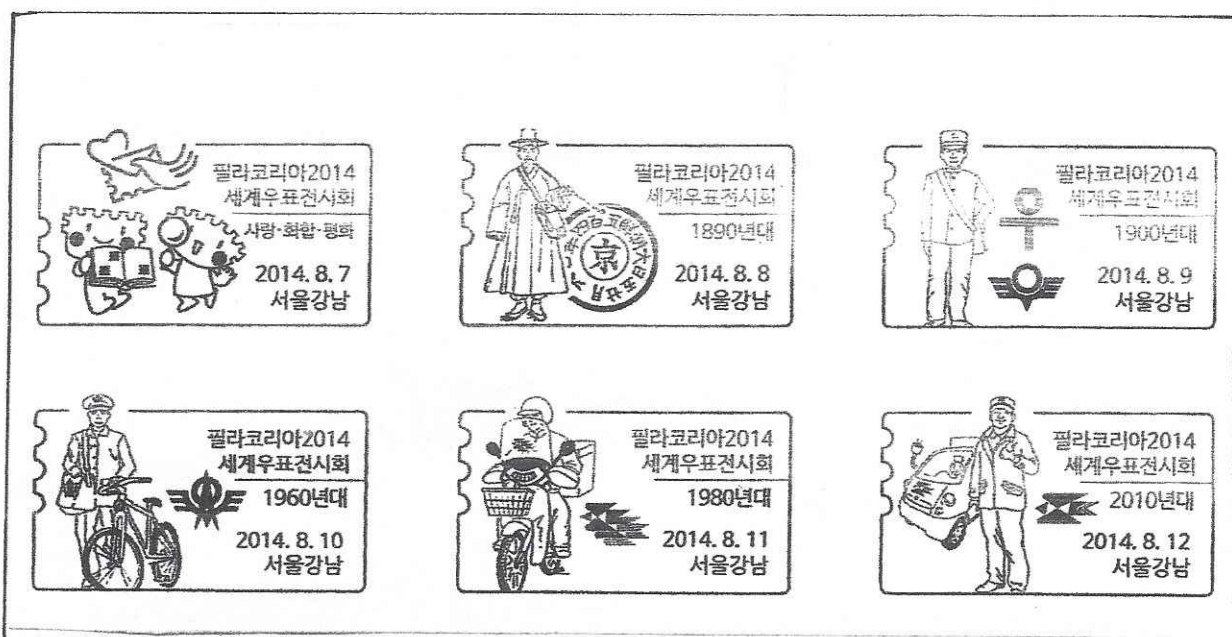



**VALENTINE DAY'S PRIVATE POST MARK & MOODY LTD 1971**

St Valentine's Day on 14 February 1971 occurred during the postal workers' strike, caused by the introduction of decimal coinage in the UK. The resourceful printers and stationers, Mark and Moody Ltd of Stourbridge, Worcestershire produced sheets of 4 labels, printed photo-offset, for St Valentine's Day. The design of each label showed a schoolboy with a satchel on a bicycle, in cartoon form. The value is shown as 1/- (one shilling, now 5p) within a heart and to the left a group of outline figures holding placards above the words "GPO STRIKE JAN '71". Each adhesive sheet measured, 5 3/4" X 9", wide enough to have printed 12 labels on a sheet! Pin rouletting separated the labels. Boys of King Edward VI Grammar School delivered the Valentine cards.

BELOW: Copy of an original sheet and an envelope, reduced, from "The Black Mailer", published by Glass Slipper. The service must have extended past 14 Feb.

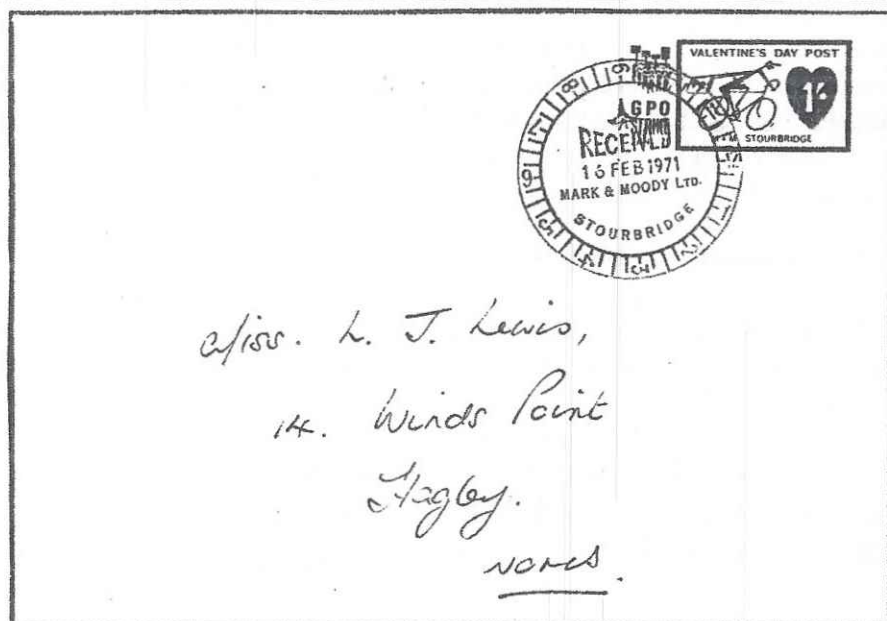
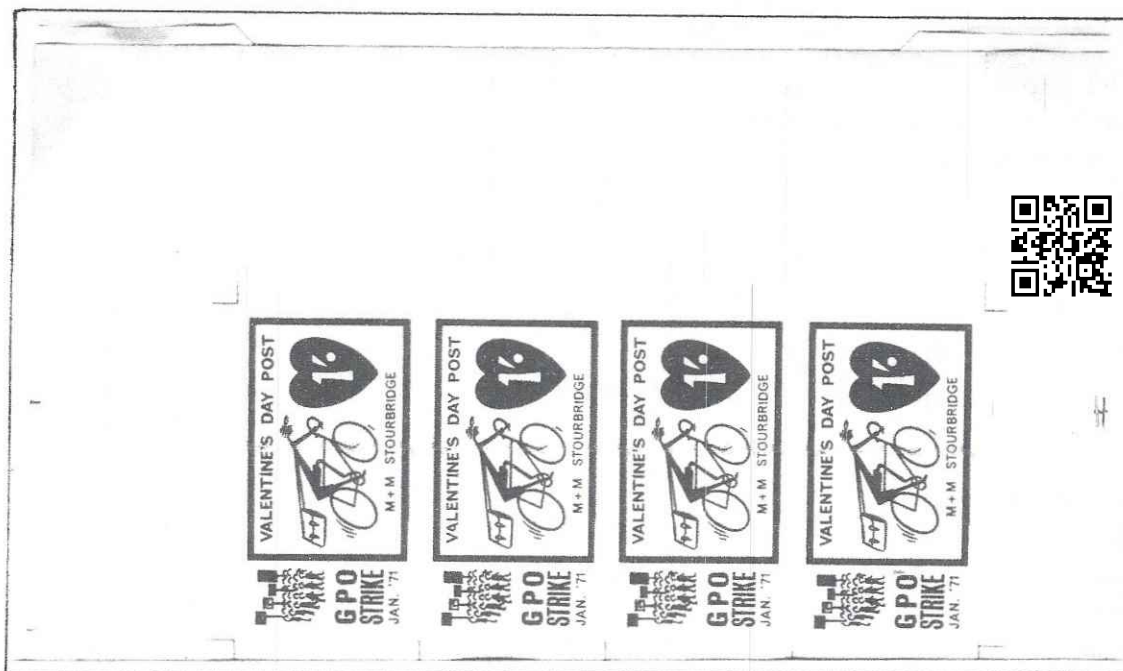

*eingetragen ✓  
Christes Katalog*

## THE MOROCCO AGENCIES CYCLE POST by Richard Garcia

(Re- printed from an article in *Stamp Mail* September/October 1990)

The British post offices of the Morocco Agencies operated in much the same way as post offices in Great Britain,

Ernest G Lomas, the clerk in charge of the British post office at Rabat, wrote to the British Postmaster at Tangier, requesting the acquisition of a 'cycle'.

"I beg to inform you that the postman here has submitted to me that with the increase in the delivery area in Rabat, the town now stretching out for two or three kilometres from the Post Office, he can no longer get through his work without a bicycle.

Mohamed has had for some year or more an old bicycle which he bought with his own money, but which has cost him since he bought it more money in repairs than he would have had to pay for a new machine. I beg to suggest that, at any rate, one bicycle for the use of the postman here is a real necessity, if we are to deliver correspondence at a respectable pace and get through the work."

Post Office Archives reveals a memo to London, dated 3 December 1931, giving details of the bicycles allocated to, or used by the postmen at the various British post offices in Morocco.

Office	Cycle or Foot post	Official or Private cycle	Number Outdoor Officers	Remarks
Casablanca	tricycle & bicycle	Official	2	1 postman & 1 contractor
Fez	cycles (2)	Private (2)	2	1 official Cycle sought
Larache	cycle	Private	1	
Marrakesh	cycle	Private	1	
Mogador	cycle	Private	1	
Rabat	cycle	Official	1	
Tangier	foot	-	2	1 postman & Contractor
Tetuan	cycle	Private	2	

Notes. Fez request for a cycle was granted. The Private cycles in use at Tetuan ceased to be used for delivery and both officers perform deliveries on foot.

Further examination of the papers reveal a most interesting letter from the British Postmaster at Tangier to the Secretary of the G.P.O. London dated 30 January 1931. An extract is quoted below and no apology is made for the story title

### The theft of the Casablanca Bicycle

"Sir

I have the honour to report that the official bicycle in use at the British Post Office Agency, Casablanca, was stolen from outside the post office premises on the 4<sup>th</sup> December last (i.e. 1930). The matter was put into the hands of the police and the bicycle was eventually found abandoned about three kilometres from the post office. Several new parts, including a bell, saddle and electric lamp, with which the bicycle had just been fitted, were missing when the machine was discovered and although the police continued their enquiries, they have not been able to trace these accessories.

This will explain why a further sum of 98 francs has been claimed in the Casablanca December 1930, account, as repairs to bicycle.

The cycle was last used by the postman who, after finishing his daily distribution placed the cycle outside the entrance to the post office. This appears to have been the practice for many year and the cycle should be reasonably safe from thieves, in which case I do not think that the postman can be held responsible for any culpable neglect.

It is a moot point whether it is advantageous to supply Agencies with bicycles. Owing to the great development of Casablanca and other Moroccan towns, distances between one poit and another are considerable and the bicycle, in careful hands, affords an easy and rapid means of locomotion and, as a saver of time, it's use is obvious. On the other hand claims for repairs are constantly being made and although occasional repairs are no doubt necessary, it is believed that much damage is caused by rough useage as the Moor treats a bicycle as he would a horse, and that is never gently. At Casablanca there are also a considerable number of bags to be carried about and the bicycle is frequently overloaded to save a journey.

In these circumstances I suggest that the Casablanca office should be supplied with a strong tricycle fitted with a commodious wooden receptacle capable of containing about four to six fair sized bags. This would simplify the question of transport and, as a tricycle cannot be traced in the same way as a bicycle, rough useage would to a great extent be eliminated.

A new porter named Mohamed ben Niss has been engaged at Casablanca as from 15th of December last, in the place of Moklouf. The latter was guilty of breaking into the parcel room in order to obtain and deliver parcels with the assumed intention of obtaining a gratuity from the addressees. The matter was reported to Tangier and the Managing Clerk was instructed to dispense with Miklouf's services, although the incident took place at a very busy time and some difficulty was experienced in finding a suitable substitute. Moklouf left of his own accord on the 15<sup>th</sup> December, after having been made to pay for the damage done to the parcel room door"

With acknowledgement to the Post Office Archive for their co-operation.

*I doubt if the Basket Carrier Tricycle (c1897) or the Centre Cycle were considered.Ed*

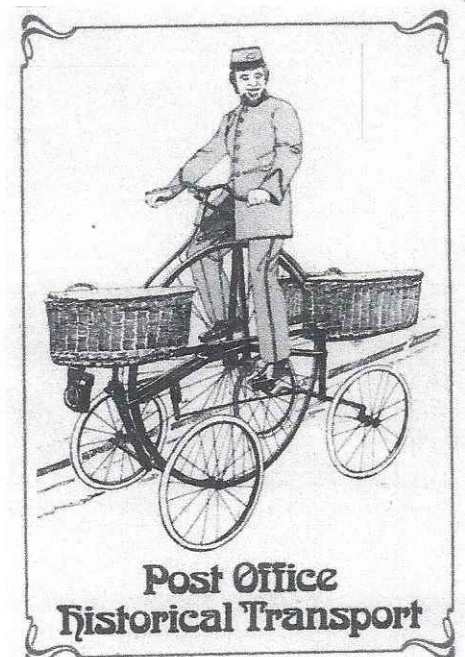
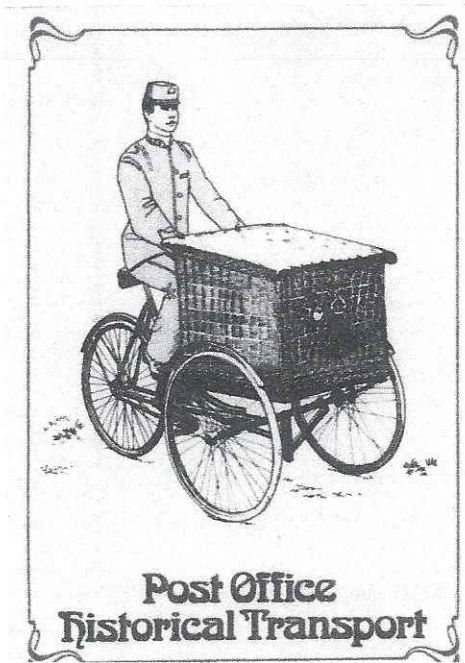



ITEM 76

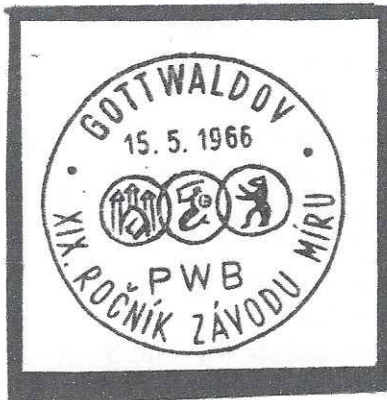

Postmarks in Czechoslovakia applied at Praha 9 May, at Liberec 10 May, Tanvald 11 May, Harrachov 11 May, Hradec Kralove 12 May, Brno 13 May, Gottwaldov (illustrated left) ) 15 May and Cesky Tesin 15 May 1966.

ITEM 77



Postmark in Germany applied at Schwerin 23 & 24 May



ITEM 78

Postmark in Poland applied at Katowice 1 on 16 May, Lodz 1 on 16 May, Warszawa 1 on 17 May, Poznan 9 on 18/19 May and Szczecin 1 on 21 May.

XX

WARSAW - BERLIN - PRAGUE 10 - 25 May 1967



**ITEM 79**

Postmark (enlarged) in Poland applied at Warszawa 1 on 2 May before the Race had started.



**ITEM 80**

Postmark (enlarged) in Poland applied at Warszawska on 5 May 1967 and also on 6th, 7th 8th and 9th May 1967



**ITEM 81**

Official First Day Cover from Poland with postmark shown as Item 79 above

Polish postmarks applied at Stage Towns  
 STAGE 2 Finish at POZNAN 9 on 11 May  
 STAGE 3 Finish at BYDGOSZCZ on 12th  
 STAGE 4 Finish at SLUPSK on 13 May  
 STAGE 5 Finish at KOSZALIN on 14 May  
 STAGE 6 Finish at SZCZECIN on 14 May  
 STAGE 7 start at SZCZECIN on 16 May  
 Stage 7 ended in Berlin.

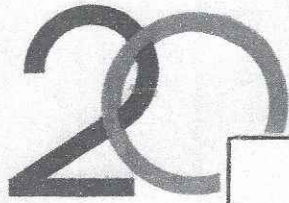

WYŚCIG POKOJU  
 ETAP II  
 KUTNO - POZ.

Introdukt 176 - IV.67 - 2850 - I - 24



WYŚCIG POKOJU  
 ETAP IV  
 BYDGOSZCZ - ŚLUPSK

Introdukt 176 - IV.67 - 2850 - I - 20

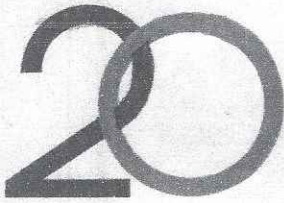

WYŚCIG POKOJU  
 ETAP IV  
 BYDGOSZCZ - ŚLUPSK

Introdukt 176 - IV.67 - 2850 - I - 20

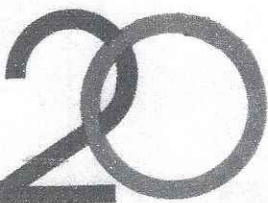

WYŚCIG POKOJU  
 ETAP VI  
 KOSZALIN - SZCZECIN

Introdukt 176 - IV.67 - 2850 - I - 24

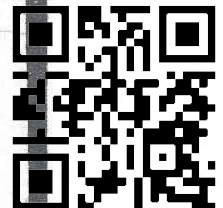
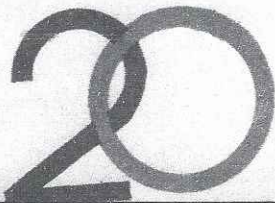

XX

WARSAW - BERLIN - PRAGUE 10 - 25 May 1967 (cont.)



ITEM 82 German postmark applied at Karl Marx Stadt 1 on 10 and 19 May 1967.



ITEM 83 Czech postmark applied at Praha on 25 May, Plzen 22 May, Usti n/Labem Liberec 24 May and Hradec Kralove on 25 May 1967

ITEM 84 (below) Czech postmark 17 April on FDI of stamp.



XXI

BERLIN - PRAGUE - WARSAW 9 - 24 May 1968



ITEM 85 (left) Polish postmark used at Warszawa on 20 - 26 May 1968.

ITEM 86 (right) Polish postmark used at Warszawa on 25 May at Katowice 21 May, Krakow 22 May 1968 and other towns (see over).





ITEM 87

Postmark  
WARSZAWA,  
Used 20-26  
May 1968.



ITEM 88

Postmark  
RZESZOW 1  
Used  
23 May 68

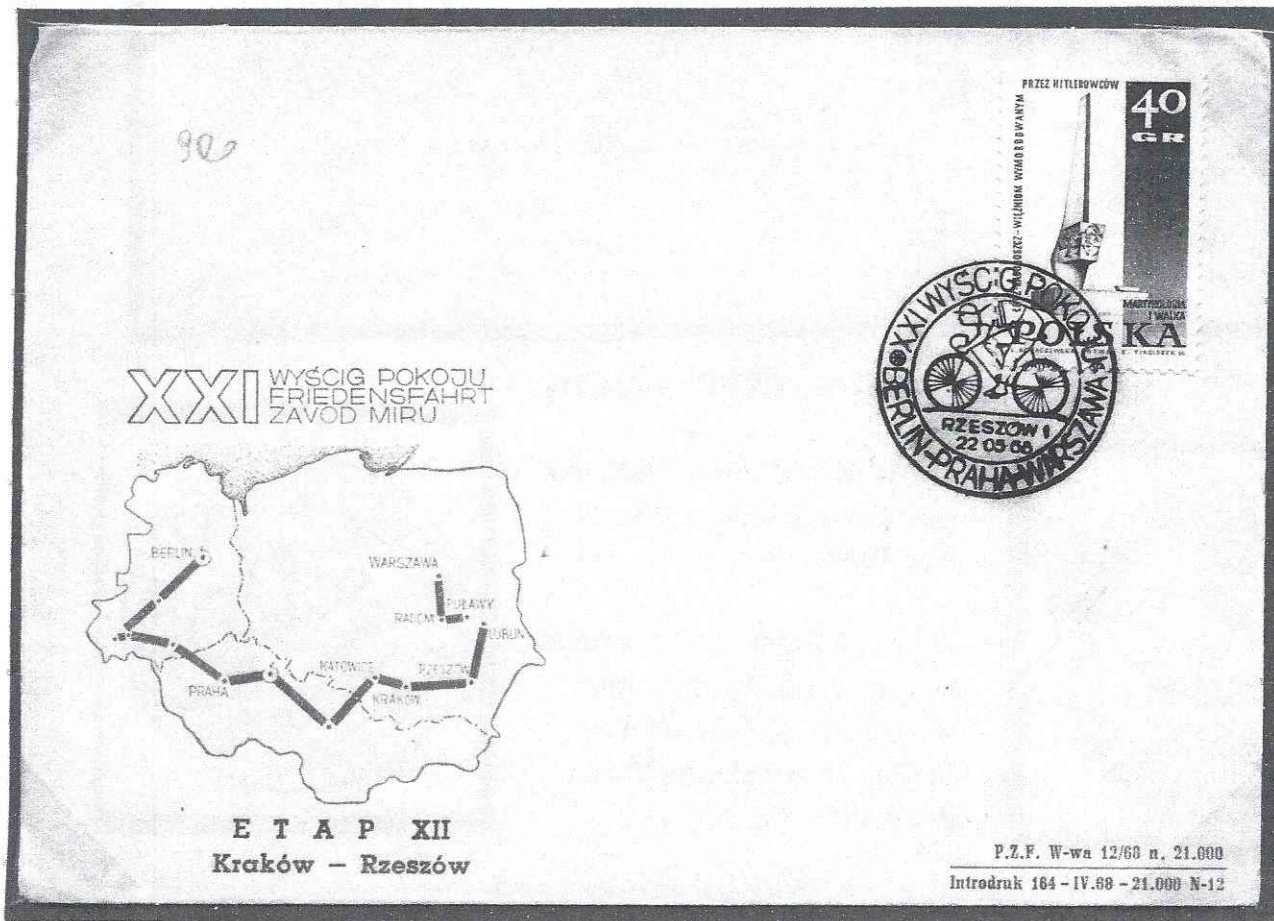



ITEM 89

Postmark  
LUBLIN 1  
Used  
23 May 68

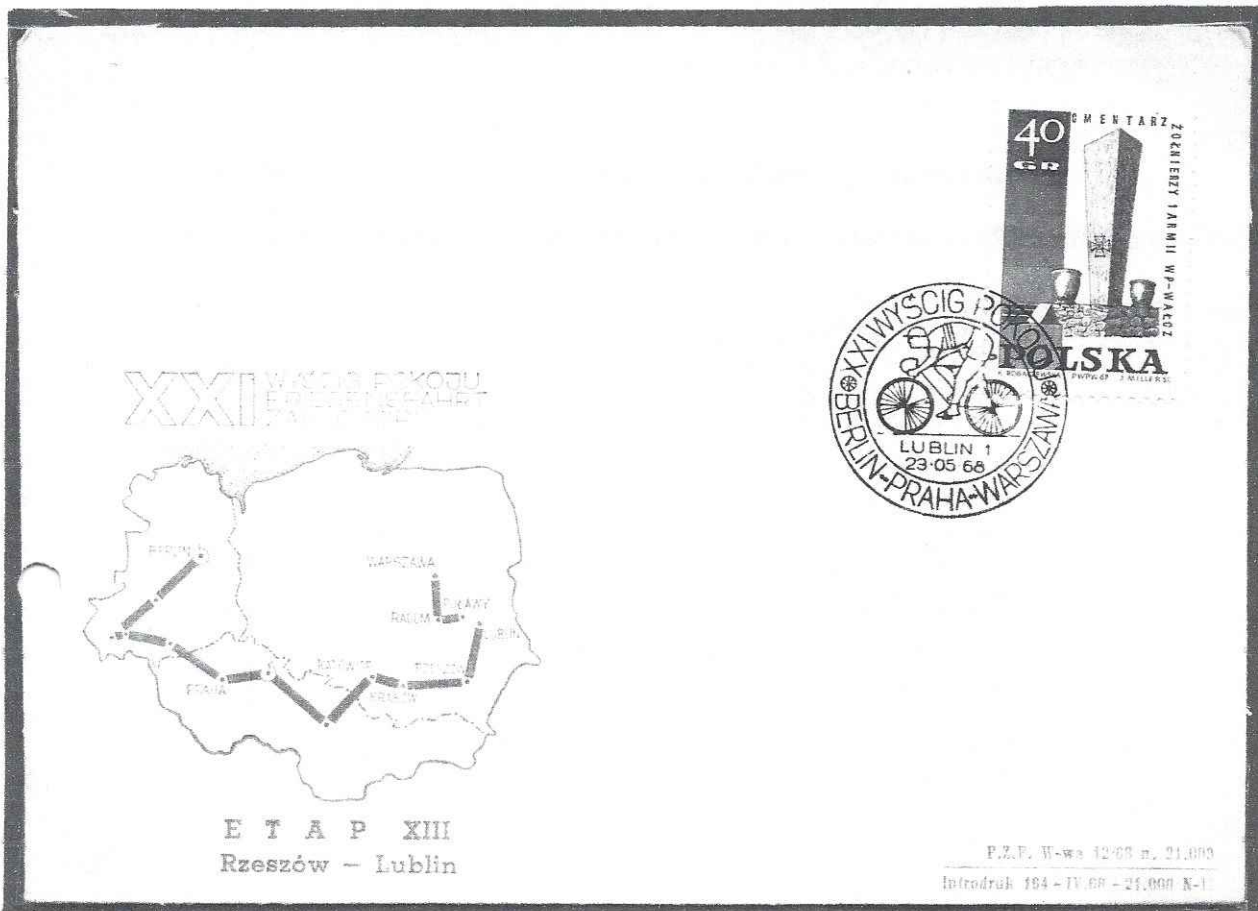

P.Z.P. W-wa 12/68 n. 21.000  
Introdruk 164-IV.68 - 21.000 N-1

ITEM 90

Postmark  
RADOM 1  
Used  
24 May 68



P.Z.P. W-wa 12/68 n. 21.000  
Introdruk 164-IV.68 - 21.000 N-12

**HAVE YOU SEEN THESE BEFORE ? QUERIES RAISED BY ARNOLDT REHM.**

A huge perfin "VELO" on 10c French stamp and a USA local mail service Sun City US 2012.

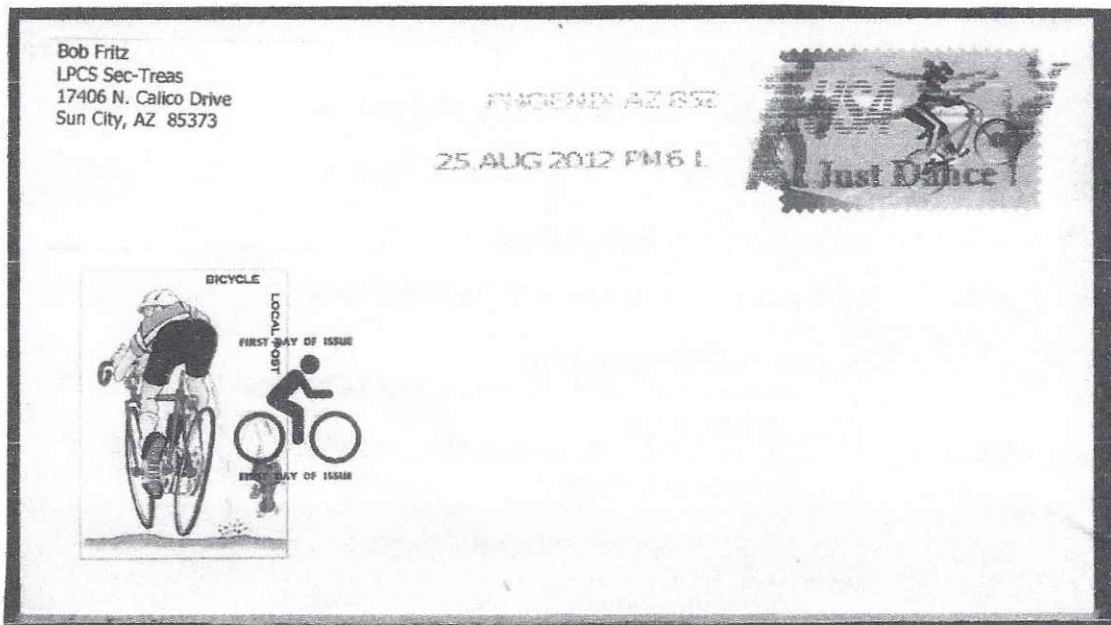

Parts making up backpedalling brake illustrated on back of envelope.

# BOSTON CYCLE AND SUNDRY CO.

BICYCLE and  
AUTOMOBILE  
SUPPLIES

J. M. LINSKOTT, MANAGER.  
Telephone 254 Haymarket

TALKING MACHINES  
SPORTING GOODS

WHOLESALE HEADQUARTERS  
48 HANOVER STREET

*Boston,* Sept. 12, 1904

Geo. C. Gifford,

W. Fishery, Mass.

Dear Sir:-

Unless we hear from you this week sending us 16 cts. in stamps for what you owe us, we shall charge our account off to Loss & Gain and strike your name from our books forever. We supposed you were honest when we gave you this small credit and you should at least be business-like enough to give it your attention now.

Yours truly,

BOSTON CYCLE & SUNDRY COMPANY.

JML-6.

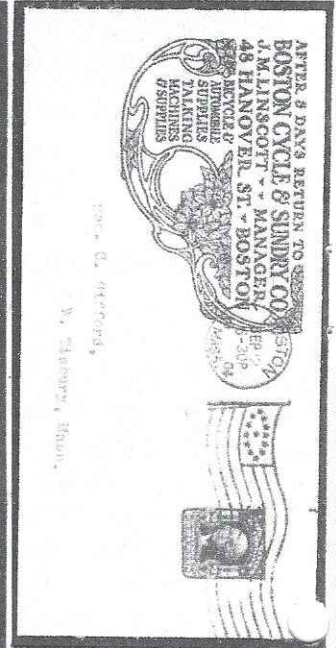

Reduced copy of letter inside envelope. The Company was very reluctant to write off 16c!

## Corbin's Duplex New Departure Coaster Brake.

Write us for Prices and  
Catalogue.

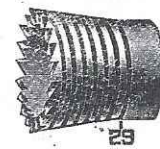
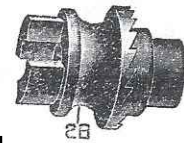
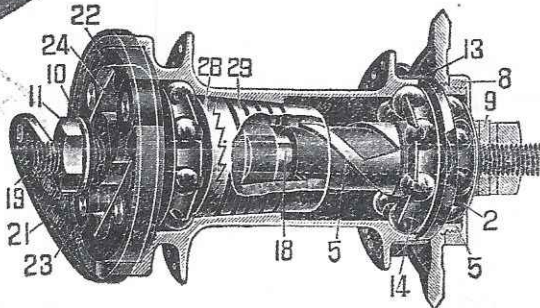

AND FINALLY – “WOT NO CYCLES?!” See Notice on lamp post.

Postcard from Littlehampton 21 July 1907, scan submitted by Arnoldt Rehm.

